

MODEL 471

Multi-Stage Alternator

- Replaces Mechanical Alternators
- User Selectable for:
 - Single Pump
 - Two Pump (duplex)
 - Three Pump (triplex)
 - Four Pump (quadraplex)

DESCRIPTION

The **Model 471 Multi-Stage Alternator** is designed to control the operating sequence of multi-stage pumping systems. It can also be used to maintain the desired level of pressure-on air compressor systems. Four PUMP SELECT DIP switches located on the front panel allow the alternator to control a single-pump, two-pump, three-pump or four-pump system. Only one switch needs to be set for the total number of pumps in the system.

The Model 471 will assure that only the necessary pumps are operating, and that the run time for each pump is approximately equal. Pumps are sequenced "first-on, first-off". If the pumping demand requires only one pump at a time, the alternator will start the next pump in sequence each time an input switch is closed. Input switches may be float switches, pressure switches, flow switches, etc., as required by the application.

Potential uses for the Model 471 include water supply systems, sewage disposal plant systems, storage tank filling systems, air compressor systems, irrigation and water recycling systems.

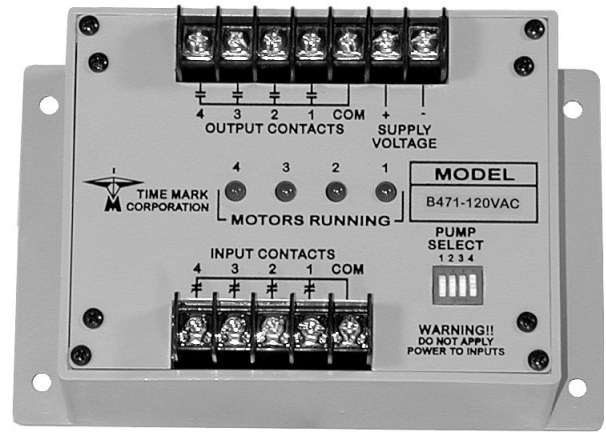

SPECIFICATIONS

MODEL	A471	B471	C471	D471
Input Voltage	24VAC 60Hz	120VAC 60Hz	240VAC 60Hz	24VDC
Power Consumption	0.5 watts max.			
Transient Protection	2500 VRMS for 10ms			
Minimum Cycle Time	100ms			
Contact Rating	SPST 2A at 240VAC resistive			
Input Contact Requirement	0.001 amp at 12VDC			
Expected Relay Life	Mech: 10 million operations Elec: 100,000 ops at rated load			
Operating Temperature	- 20° to +140° F			
Humidity Tolerance	0 - 97% w/o condensation			
Enclosure Material	ABS plastic			
Weight	1.2 lbs.			

DIMENSIONS

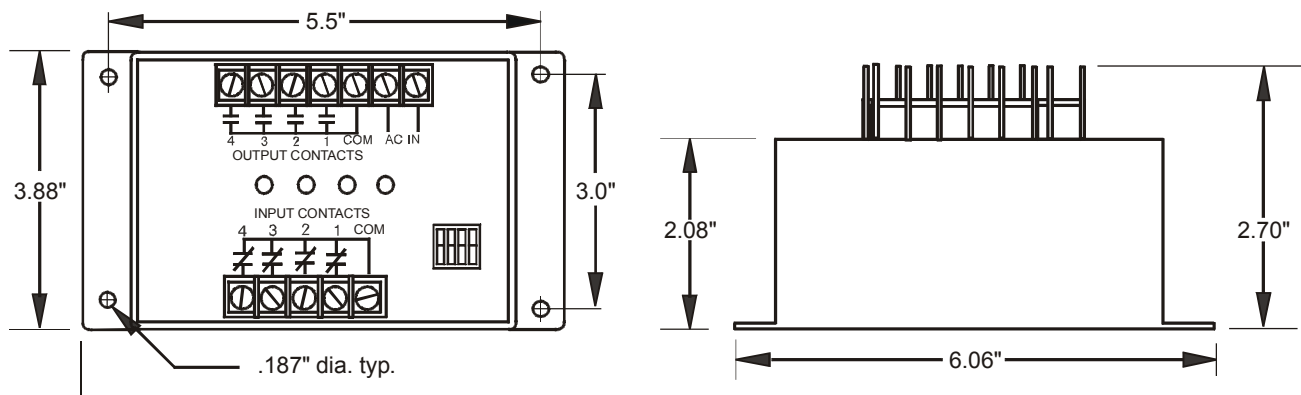

TIME MARK
CORPORATION

11/2011
© 2011 TIME MARK CORPORATION

TIME MARK is a division of  AEMT, Inc.

MODEL 471 Multi-Stage Alternator

READ ALL INSTRUCTIONS BEFORE INSTALLING, OPERATING OR SERVICING THIS DEVICE.
KEEP THIS DATA SHEET FOR FUTURE REFERENCE.

GENERAL SAFETY

POTENTIALLY HAZARDOUS VOLTAGES ARE PRESENT AT THE TERMINALS OF THE MODEL 471.
ALL ELECTRICAL POWER SHOULD BE REMOVED WHEN CONNECTING OR DISCONNECTING WIRING.
THIS DEVICE SHOULD BE INSTALLED AND SERVICED BY QUALIFIED PERSONNEL.

Installation Instructions

INSTALLATION

Mount the Model 471 in an appropriate enclosure or panel.

Connect AC power connections to the terminals marked AC IN. **Do not apply power** until all other connections are made.

Connect the input switches (float, pressure, etc.) to the terminals marked INPUT CONTACTS.

One side of each input switch is connected to the common terminal; the other side should be connected to the input terminals, starting with terminal 1.

Terminal 1 will be the first selected for either the pump up or the pump down application. See the TYPICAL APPLICATION diagram.

Connect the control circuits of the pumps or motors to be alternated to the terminals marked OUTPUT CONTACTS, again beginning with terminal number 1. Refer to the TYPICAL APPLICATION diagram.

ADJUSTMENT

Set one of the four PUMP SELECT DIP switches to the ON position, to indicate the total number of pumps or motors in the system. For example, for a 4 pump system, set the number 4 DIP switch to ON.

For a 2 pump system, set only switch 2 to ON. This limits the alternator to the first two outputs. If more than one switch is set to ON, the lowest numbered switch takes priority.

If a pump or motor must be removed for servicing or replacement, shift the higher numbered input and output connections towards the number 1 terminal, to fill in any gaps in the switching process.

PUMP DOWN APPLICATION

In a "Pump Down" application, the switches are normally-open. As the liquid level rises, the number 1 level switch closes, turning on the first pump. If the level continues to rise, additional pumps are turned on.

As the level drops, the pumps or motors are turned off on a first-on/first-off basis. When the low level switch opens, the Model 471 alternates to the next pump for the next operating cycle. Switch number 1 determines when alternation occurs.

PUMP UP APPLICATION

In a "Pump Up" application, the switches are normally-closed. When the reservoir is full, the switches will be open. As the liquid level drops the number 1 level switch closes, turning on the first pump. If the level continues to drop, additional pumps are turned on.

When the level rises above the number 1 switch, the switch opens, turning off the pump. The Model 471 then alternates to start the next pump in line for the next operating cycle. The number 1 switch determines when alternation occurs.

WARRANTY

This product is warranted to be free from defects in materials and workmanship for one year. Should this device fail to operate, we will repair it for one year from the date of manufacture. For complete warranty details, see the *Terms and Conditions of Sales* page in the front section of the Time Mark catalog or contact Time Mark at 1-800-862-2875.

TYPICAL APPLICATION

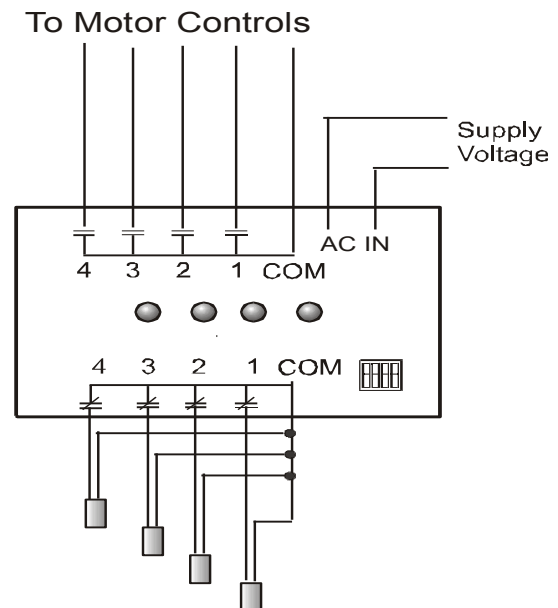

TIME MARK
CORPORATION

11/2011

© 2011 TIME MARK CORPORATION

TIME MARK is a division of  AEMT, Inc.